

Permit Application

Town of Blaine Lake

PO Box 10
Blaine Lake, SK S0J0G0
(306) 497-2531
blainelake@sasktel.net

APPLICATION B - BUILDING & DEVELOPMENT PERMIT

Attached Garage

Applicant

Name: _____

Address: _____

Telephone number: _____

Property Legal Description:

Lot: _____ Block: _____ Plan: _____

Lot Size (Dimensions) : _____

Contractor name and contact information (if used):

Intended use of building: _____

Size of Building: _____

Please provide detailed site plan and indicate:

- (Circle one) Construction / Alteration / Reconstruct
- Building area (area of largest storey)
- Estimated value of construction

I hereby agree to comply with the Building Bylaw of the local authority and acknowledge that it is my responsibility to ensure compliance with the Building Bylaw of the local authority and with any other applicable bylaws, acts and regulations regardless of any plan review or inspections that may or may not be carried out by the local authority or its authorized representative.

Date: _____

Signature: _____

Permit Fee: \$ _____ (\$1.00 for every \$1,000 of estimated construction value)

New Construction / Development:

If the building is to be for temporary use, please indicate. (Temporary use - short term structures, to be dismantled or moved)

Please indicate the number of sets of stairways, storeys, fire escapes, exits, soil type - if applicable.

Please attach a separate sheet with the following information:

Material & Size of:

Exterior Walls	Roof
Studs	Floor Joists
Girders	Rafters
Chimney	Heating
Lighting	Plumbing

*See attached for more info

Declaration of Applicant:

I, _____ of the _____ in SK, do solemnly declare that the above statements are true. I make this declaration believing it to be true, and knowing that it is of the same force and effect as if made under oath. I agree to indemnify and hold harmless the Town of Blaine Lake from and against any claims, demands, liabilities, costs and damages related to the development.

(sign on the left hand side)

ATTACHED GARAGE WORKSHEET

Please complete the following:

ROOF:

- Roofing:
- Asphalt Shingles
 - Metal Roofing
 - Other: _____
- Roof Sheathing:
- OSB
 - Plywood
 - Other: _____
- Thickness of Sheathing:
- 3/8"
 - 7/16"
 - Other: _____
- Roof Structure:
- Pre-engineered
 - Other: _____

Provide additional information (size, spacing, ...etc.)

Spacing of Trusses:

- 16" o.c.
- 24" o.c.

Roof Overhang (a): _____

FOUNDATION:

- Depth of Existing House Foundation: _____
- Foundation Wall
- Wall:
- Height _____ x Thickness _____
 - Footing: Height _____ x Thickness _____

Grade Beam and Piles

- Grade Beam:
- Width _____ x Depth _____
 - Reinforcing _____
- Pile:
- Diameter _____ x Depth _____
 - Reinforcing _____

SITE PLAN:

Size of Proposed Garage: _____

- Indicate the following:
- Distance to Rear Property Line (c)
 - Distance to Side Property Line (d)
 - Location and size of all doors and windows (i.e. the walls in which they are installed)
 - All existing buildings on lot
 - Dimensions and shape of lot

If not rectangular, provide actual dimensions or provide separate site plan

NOTE: Soffit projections must not project to less than 0.45m from the property line.

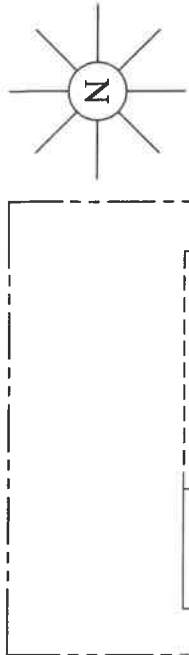
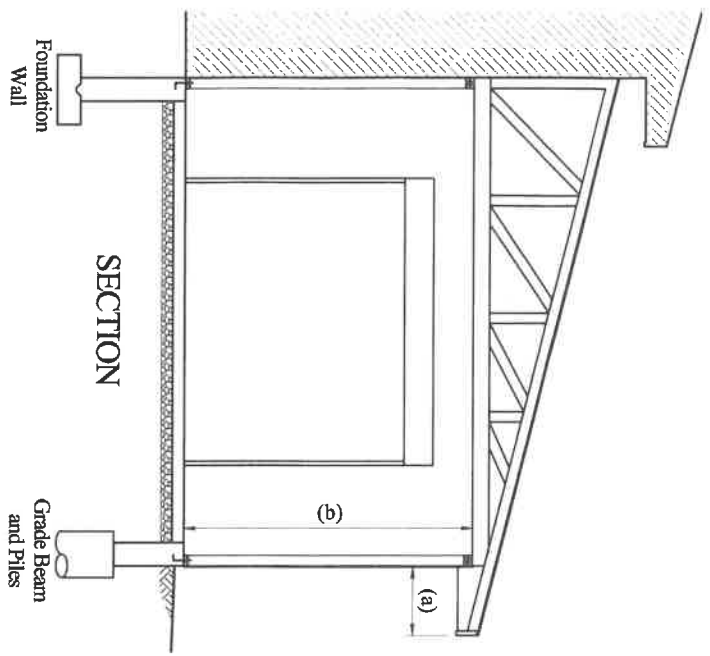

SITE PLAN

WALLS:

- Exterior Siding:
- Vinyl
 - Hardboard
 - Air Barrier
 - House Wrap
 - Wall Sheathing:
 - OSB
 - Plywood
- Thickness of Sheathing:
- 3/8"
 - 1/2"
 - Other: _____

Wall Framing: 2x _____ @ _____ 16" o.c. _____ 24" o.c.

Height of Exterior Walls (b): _____

Wall Anchorage:

- 3/8" Bolts
- 1/2" Bolts

Spacing of Bolts: _____

Lintel Size and Number of Piles for:

- Man Door(s): 2 3 - 2x _____
- Window(s): 2 3 - 2x _____
- Size of Window: _____ x _____
- Overhead Door(s): 2 3 - 2x _____
- Size of Overhead Door: _____ x _____

INTERIOR FINISHES:

- Will the garage:
- have insulation installed Yes No
 - have vapour barrier installed Yes No
 - have interior finishes installed Yes No
 - have any plumbing fixtures Yes No
 - be heated Yes No

DOOR (INTO HOUSE):

- Weather stripped
- Self-closer
- Deadbolt Lock
- Blocked at lock-height to frame
- Hinges secured to solid wood frame
- No operable windows

NOTE: Air duct systems cannot be interconnected with other parts of dwelling unit.

Owner's Name: _____

Address: _____

Municipality: _____

Provided by: **MUNICODE SERVICES**

8 RESIDENTIAL DISTRICT - R1

No person shall within any R1-Residential District use any land or erect, alter or use any building or structure, except in accordance with the following provisions:

8.1 PERMITTED USES

- a) One single detached dwelling;
- b) Uses, buildings and structures accessory to the foregoing permitted uses and located on the same site with the main use;
- c) Playgrounds and swimming pools;
- d) Public works buildings and structures excluding offices, warehouses, and storage yards.

8.2 DISCRETIONARY USES

The following uses may be permitted in the R1-Residential District only by resolution of Council and only in locations specified by Council:

- a) Home Occupations;
- b) Child and adult daycare;
- c) Secondary Suites;
- d) Semi-detached and duplex dwellings;
- e) Bare land Condominiums;
- f) Modular homes;
- g) Bed and Breakfast homes;
- h) Personal care homes;

No person shall initiate any permitted, discretionary or accessory use prior to obtaining a development permit from the Development Officer.

8.3 SITE DEVELOPMENT REGULATIONS

Single Detached Dwellings

Minimum site area	467 m ² with a lane or 604 m ² without a lane
Minimum floor area	75 m ²
Minimum site frontage	15.0 metres with a lane or 18.0 metres without a lane Non-rectangular sites: With a rear lane: 10.6 metres with a mean width of 15.24 metres. Without a rear lane: 15.24 metres with a minimum mean width of 18metres.
Height	9.0 metres for the Principal building and 5.0 metres for accessory buildings

*Amended
Bylaw 2017-08*

Maximum site coverage	40%
Minimum front yard	6.0 metres
Minimum rear yard	7.5 metres
Minimum side yard	1.5 metres unless on a corner site than the side yard shall be 6.0 metres
Minimum parking spaces	2

8.4 ACCESSORY BUILDINGS

- a) All accessory buildings shall be set back a minimum of 7.0 metres from the front site line, 1.2 metres from the principal building, and 0.8 metres from the side site line unless the side site line is an abutting street then the side yard shall be 3.6 metres.
- b) All accessory buildings shall not exceed 83.6 m² (900 ft²) in area. *See Amendment Bylaw-2017-02*
- c) All accessory buildings shall be located a minimum of 0.8 metres from the rear site line except where an accessory building has a door or doors opening onto a lane then it shall not be located less than 1.5 metres from the site line abutting the lane.
- d) All activities related to artisan studios, crafts and workshops shall be conducted within an enclosed building. No exterior storage of materials, goods, or waste products is permitted, except within a waste disposal bin for collection.
- e) Temporary, fabric covered structures consisting of wood, metal or plastic framing covered on the roof and one or more sides with fabric, plastic, vinyl or other sheet material shall be permitted in a rear or side yard.

8.5 SIGNAGE

- a) One permanent sign is permitted per site;
- b) In the case of a home occupation, an additional permanent sign is permitted in a window of a dwelling, affixed to the dwelling or accessory building or free standing on the property at least 3 metres in from any lot line;
- c) The facial area of a sign shall not exceed 0.5 m²;
- d) No sign shall be located in any manner that may obstruct or jeopardize the safety of the public;
- e) Temporary signs not exceeding 1.0 m² advertising the sale or lease of the property or other information relating to a temporary condition affecting the property are permitted.

Town of Blaine Lake Bylaw No. 2017 - 08

Zoning Bylaw Amendment

A Bylaw of the Town of Blaine Lake in the Province of Saskatchewan to amend Bylaw No. 2013-05 known as the Zoning Bylaw.

The Council of the Town of Blaine Lake in the Province of Saskatchewan in open meeting hereby enacts as follows:

Bylaw No. 2013-05 is amended as follows:

1. Section 8.3 Height

9,0 m (29.5 ft) for the Principal Building

2. Section 8.4 b)

All accessory buildings shall not exceed 111.5 m² (1200 ft²) in area and a maximum wall height of 3.1 m (10 ft)

3. Section 9.3 Height

9,0 m (29.5 ft) for the Principal Building

4. Section 9.4 c)

All accessory buildings shall not exceed 111.5 m² (1200 ft²) in area and a maximum wall height of 3.1 m (10 ft)

Read a 1 st time	<u>June 23/17</u>
Advertised a 1 st time	<u>July 21/17</u>
Advertised a 2 nd time	<u>July 28/17</u>
Public Hearing	<u>August 16/17</u>
Read a 2 nd time	<u>August 16/17</u>
Read a 3 rd & final time	<u>August 16/17</u>

Mayor:

(SEAL)

